

ELIE 70CL

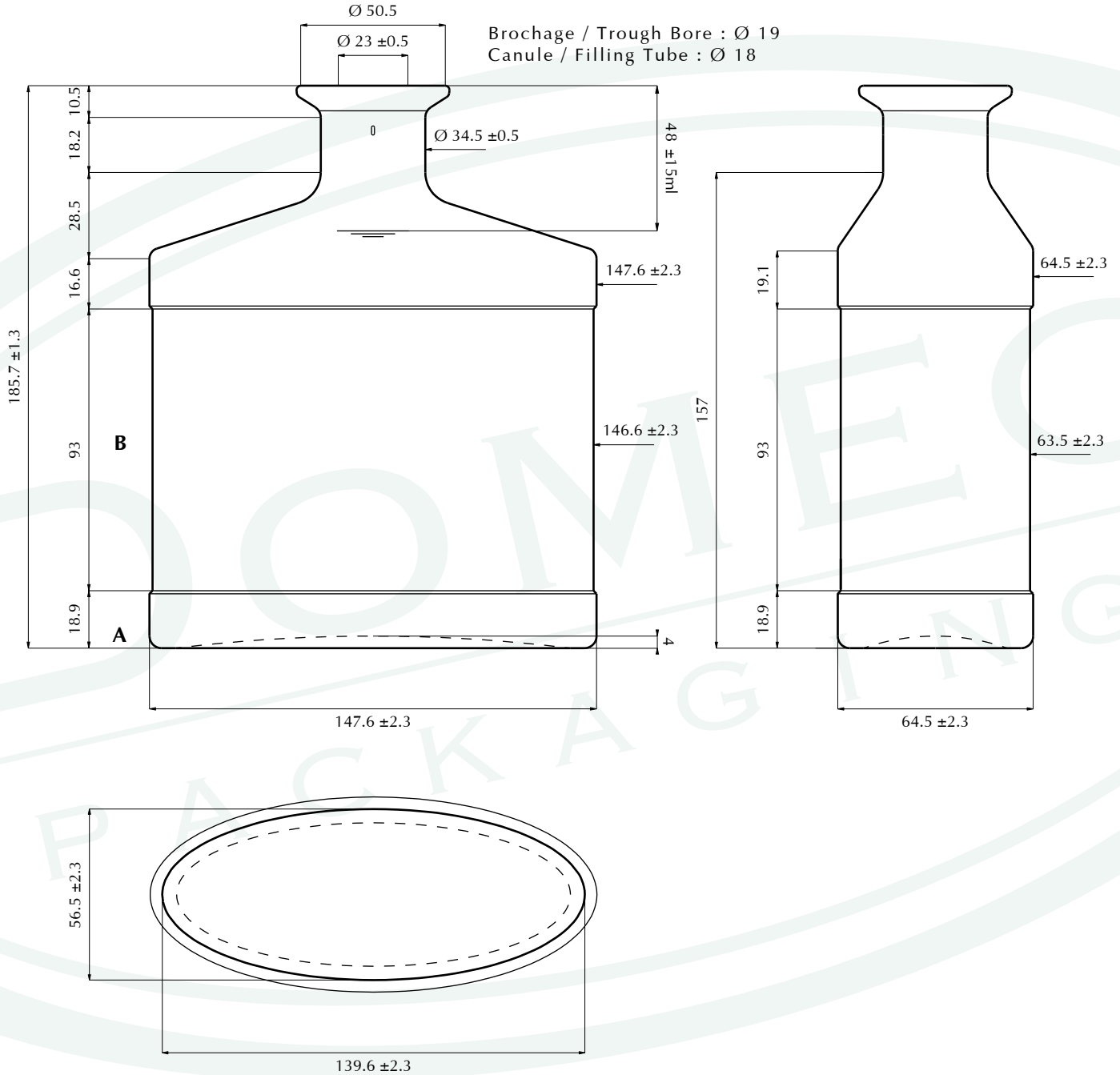

Visuel 3D



MODELE / MODEL	CAPACITE / CAPACITY (CL)	POIDS / WEIGHT (GR)	TEINTE / COLOUR	HAUTEUR / HEIGHT (MM)
ELIE	73.2	800	EXTRA BLANC	185.7
BAGUE / FINISH (MM)	DEBOUCHAGE / ENTRANCE (MM)	SECTION A (MM)	SECTION B (MM)	CODE
Norme NFH 35-081				
CARNETTE	23	147.6 x 64.5	146.6 x 63.5	2-ELI-70-CA-D

Echelle / Scale 1:2