

ANTIQUE 75CL

ECHELLE

1:2

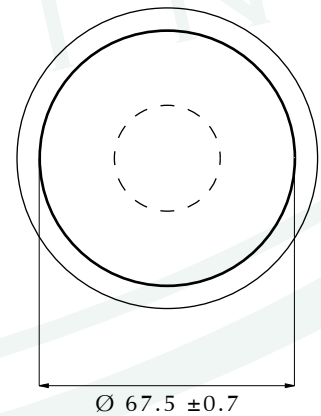
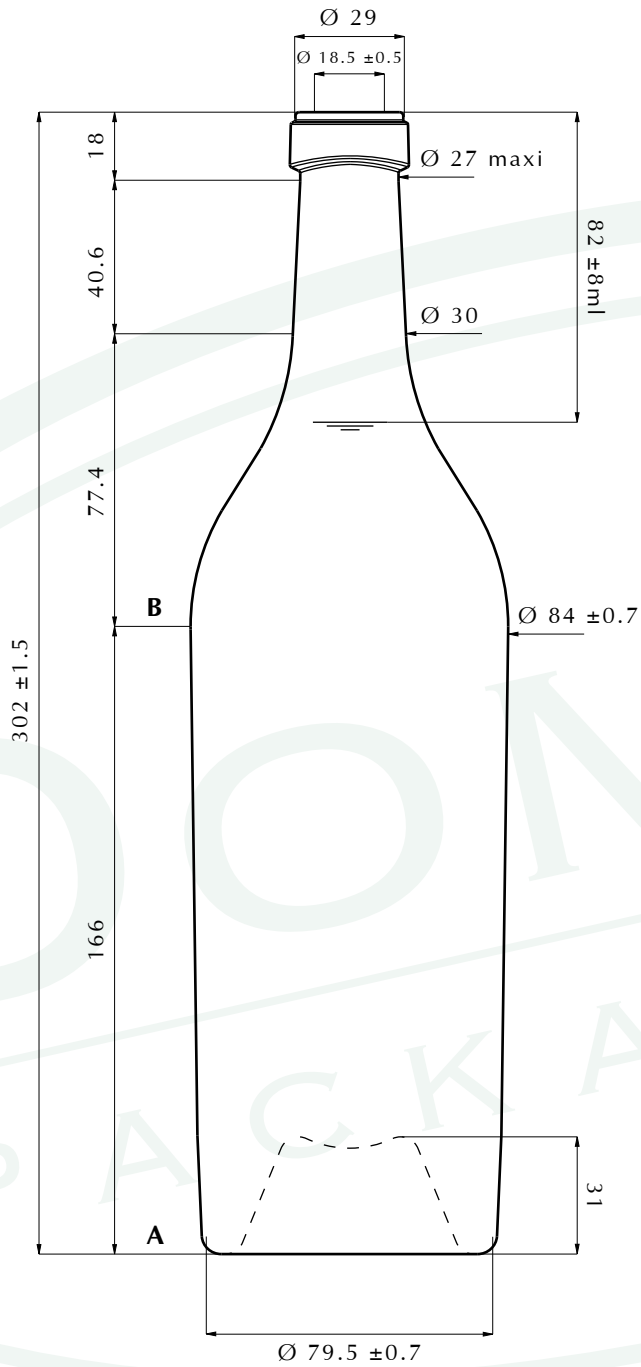

MODELE	CAPACITE (CL)	POIDS (GR)	TEINTE	HAUTEUR (MM)
ANTIQUE	78	705	CITRINE	302
BAGUE (MM)	DEBOUCHAGE (MM)	SECTION A (MM)	SECTION B (MM)	PALETTISATION
BBT 29	18.5	79.5	84	540